

ALUMINUM FOLDING CLOSURES

Our flexible custom built, interior mounted, aluminum folding closures, or sliding grills, provide a wide range of enclosures for store fronts, or to demise spaces.

Imaginative engineering of our sliding grills allows for straight or curved runs, ones, glass or polycarbonate inserts, push pad emergency egress door handles, and more.

If your environment is wet, then we will utilize stainless steel hardware ,that used in conjunction with aluminum extruded panels, means no rust worries.

We can supply our folding curtains in heights up to 16 feet , depending on the model, and in lengths up to 200 feet long, in a variety of styles, , in a contiguous span, or bi-parted as required. We also offer standard ,and optional colors, with certain models, as well.

The folding curtains can smoothly slide side to side and be stacked in line, or out of sight in a pocket wall, with no maintenance plagued costly motors.

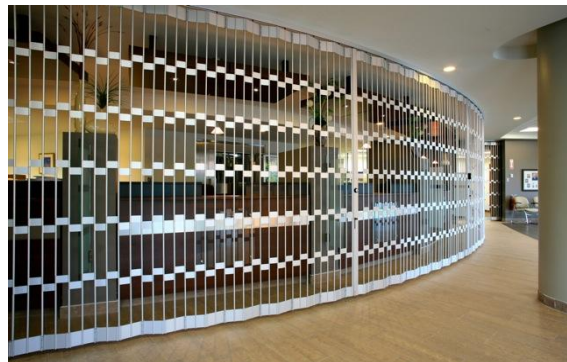

SEE PAGES 7-10 FOR DESIGNS AND IMAGES



1-800-835-0214

XPANDASECURITYGATES.COM
INFO@XPANDASECURITYGATES.COM

FOLDING CLOSURE DETAIL MODEL IMPACT

FOLDED CLOSURE NEEDS APPROXIMATELY 15% OF CLEAR OPENING FOR STACKING

TROLLEY WHEELS RUN IN TRACK

PLASTIC HANDLE

LEAD POST WITH HOOK LOCK AND 5 PIN CYLINDERS

CONTINUOUS OVERHEAD TRACK, CURVED OR STRAIGHT

TOP 4" (102mm) ALUMINUM SUPPORT PANEL

CHOICE OF INFILL OPTIONS: GLAZED, SOLID, PERFORATED OR GRILLE PATTERNS

PVC PROTECTOR

INTERMEDIATE POST WITH DROP BOLT, MAXIMUM 10'0" (2500mm) ON CENTER

BOTTOM ALUMINUM ADJUSTMENT PANEL

DUSTPROOF SOCKET SET INTO FLOOR

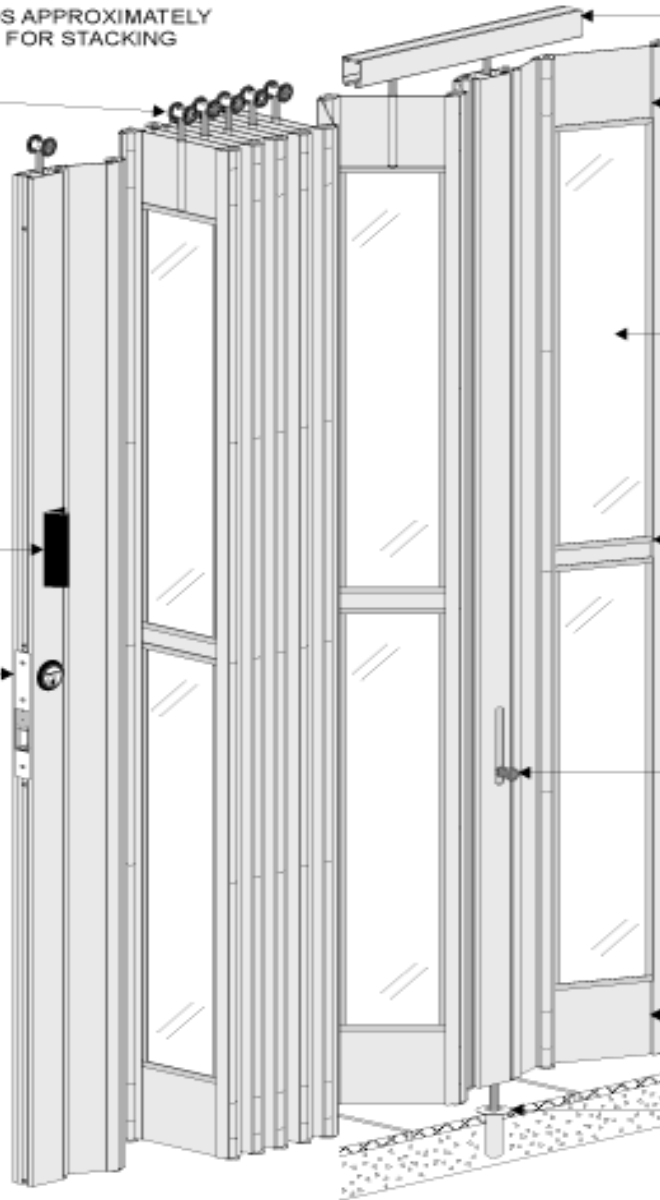

1-800-835-0214

XPANDASECURITYGATES.COM
INFO@XPANDASECURITYGATES.COM

ELEVATION MODEL IMPACT

POLYCARBONATE SIDE FOLDING CLOSURE

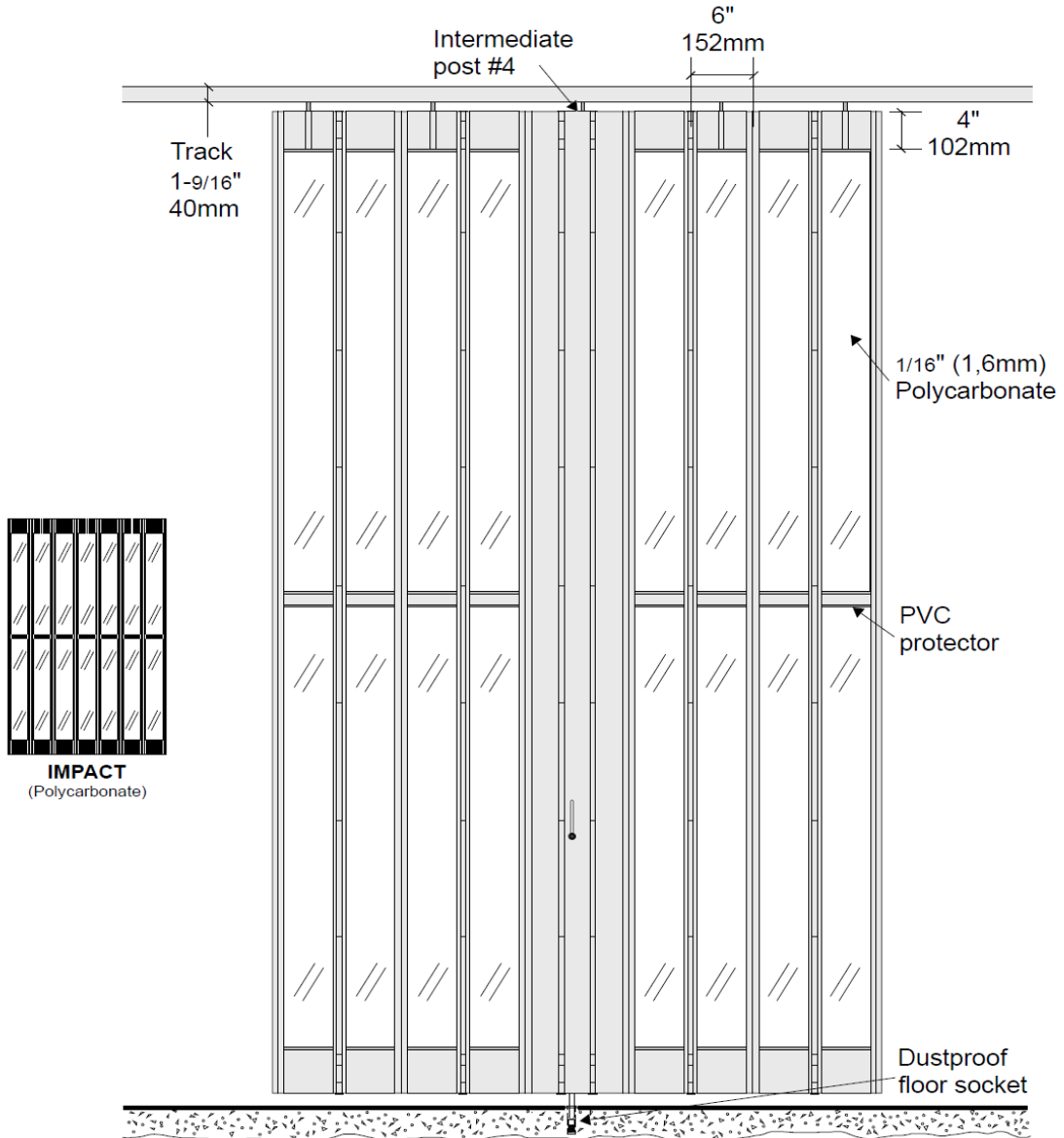

SUPPORT STRUCTURE POSSIBILITIES

RECTANGULAR TUBING SUPPORT ALUMINUM OR STEEL

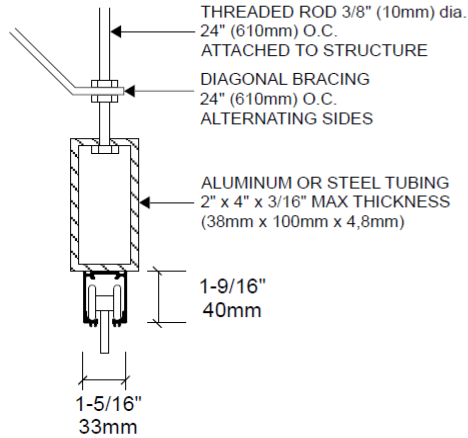

5" X 3" (127x76mm) ANGLE SUPPORT AND WOOD, FACE TO WALL MOUNT

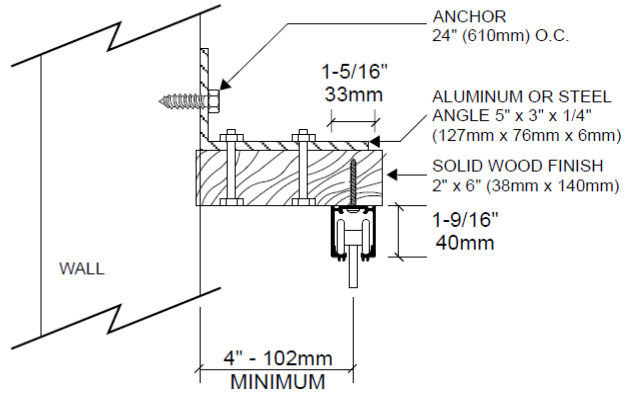

SQUARE TUBE SUPPORT ALUMINUM OR STEEL

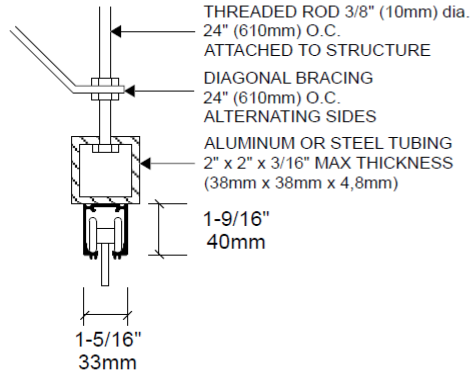

ANGLE SUPPORT, FACE TO WALL MOUNT

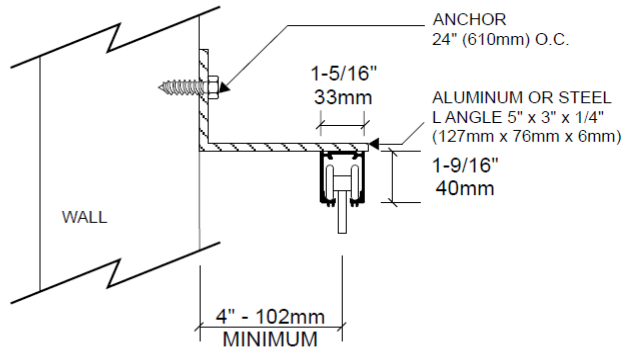

SUPPORT BUILT BY GENERAL CONTRACTOR
 MINIMUM WEIGHT CAPACITY OF 3 lb / sq. ft (15 kg / sq.m) OF GRILLE

SUPPORT STRUCTURE POSSIBILITIES

METAL STUD AND PLYWOOD BULKHEAD SUPPORT

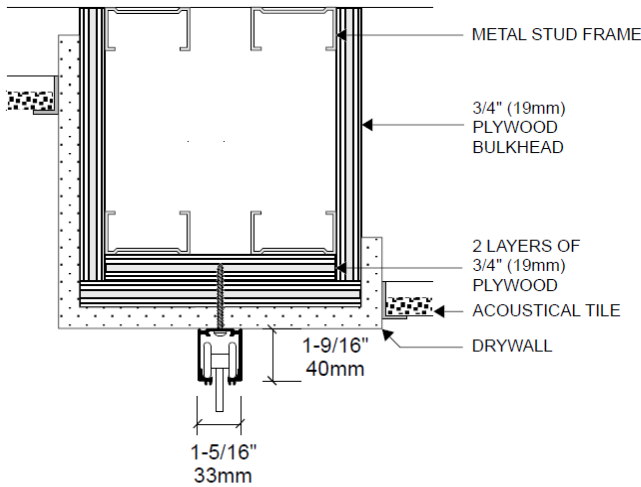

STEEL BEAM AND WOOD SUPPORT

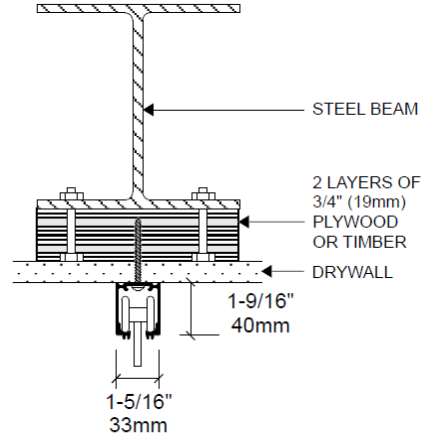

UNISTRUT SUPPORT

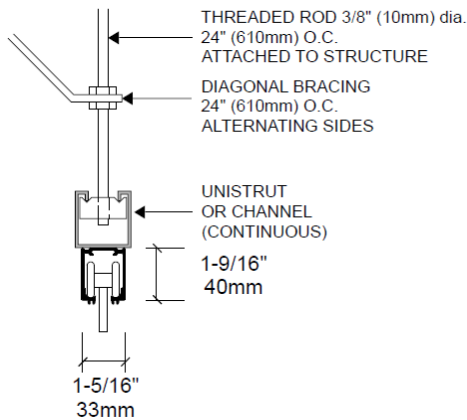

SUPPORT BETWEEN JOISTS (EVERY 36" (914mm) O.C.)

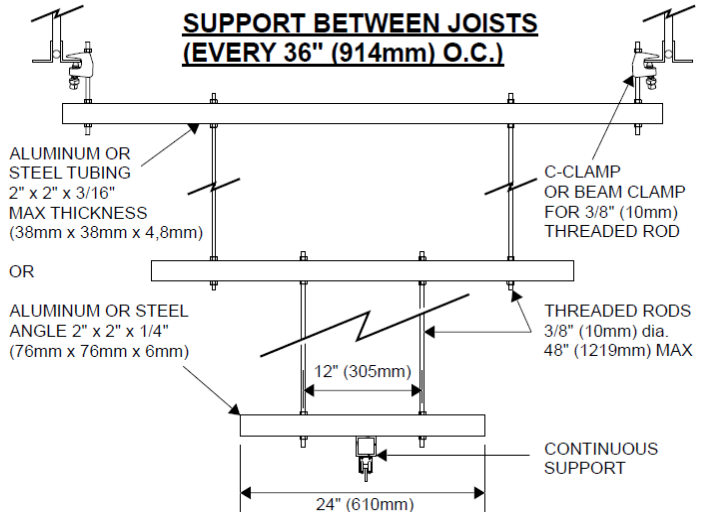

SUPPORT BUILT BY GENERAL CONTRACTOR
 MINIMUM WEIGHT CAPACITY OF 3 lb / sq. ft (15 kg / sq.m) OF GRILLE

STACKING OPTIONS

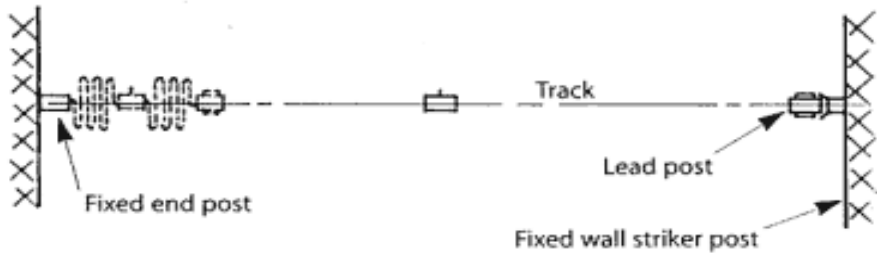
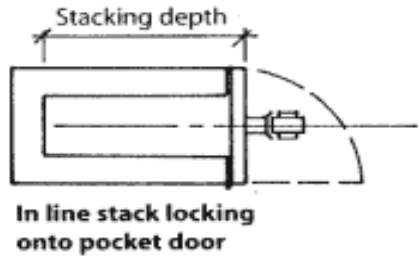
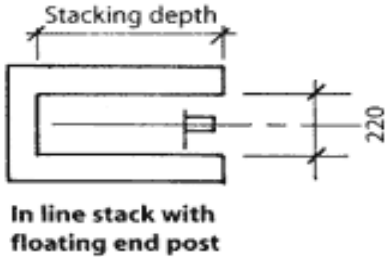
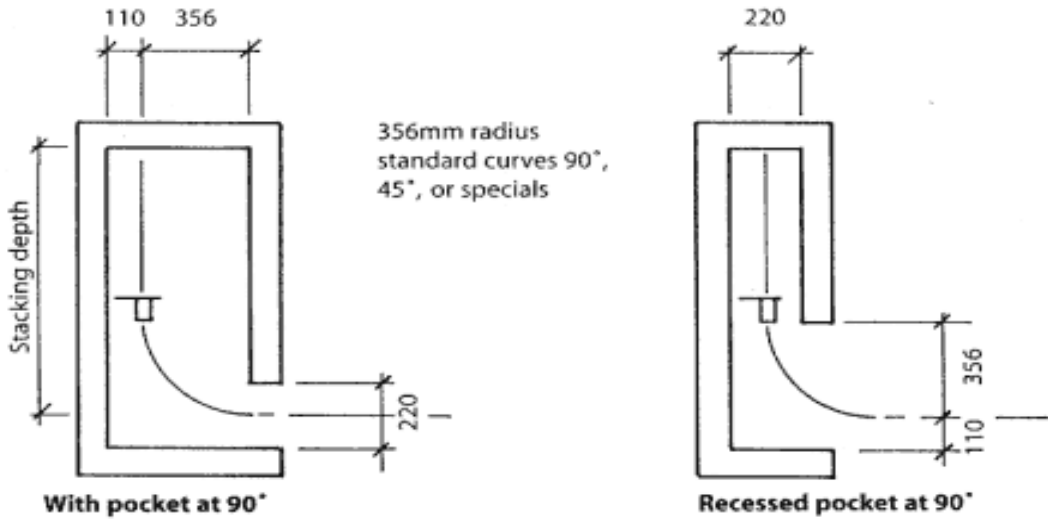

Between Jambs - No Pocket

Note

There are no floor tracks.
 Integral intermediate posts are at max 3000mm centres, except on counter tops when they are at approximately 1500mm centres.
 Stacking depth - allow 95mm per 1000mm of clear opening length plus 76mm per post member including the end post, lead post, and intermediate posts.



Sliding and Folding Grille Models

ROYAL

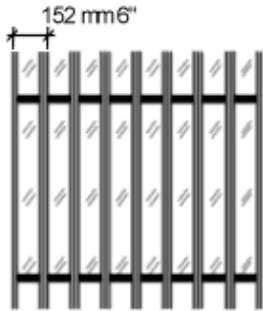

IMPACT

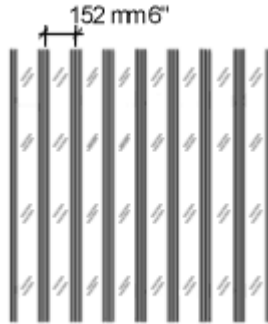

S-126

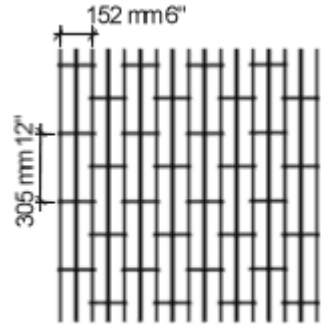

CONCEPT 66

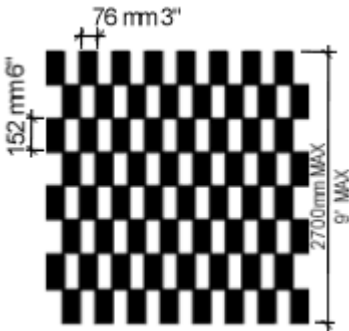

CONCEPT 99

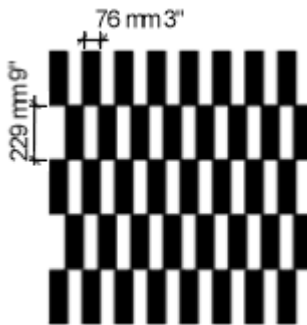

CONCEPT 1212

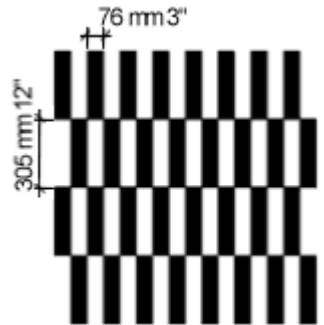

S-525

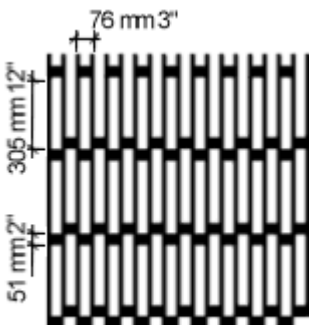

GLOBAL

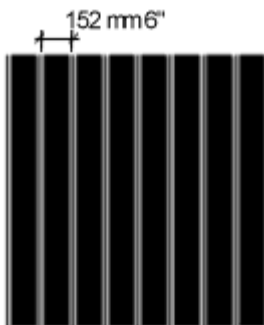

AEROFLEX

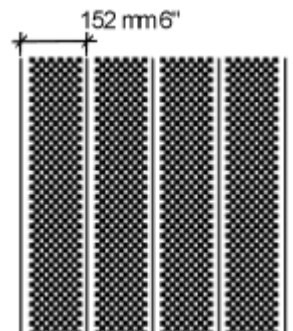

CONCEPT 99



S-525



S-525

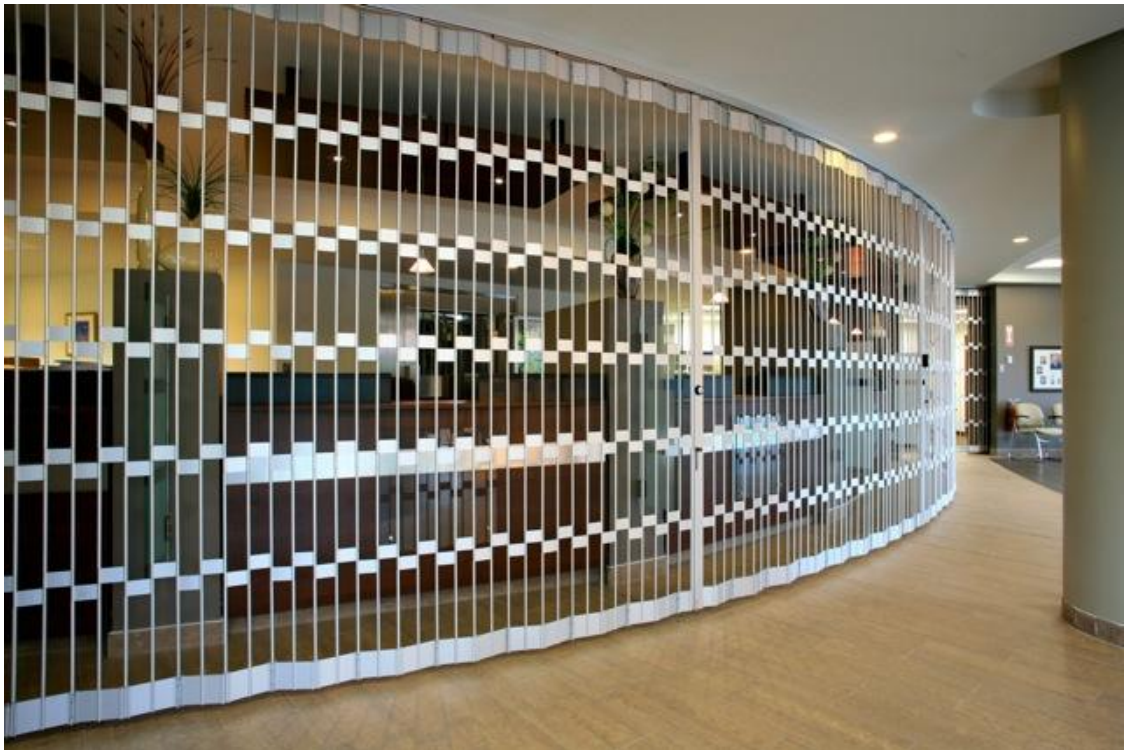



S-126





AEROFLEX



AEROFLEX



GLOBAL



ROYAL



1-800-835-0214
XPANDASEcurityGATES.COM
INFO@XPANDASEcurityGATES.COM